

Temposonics®

Magnetostrictive Linear-Position Sensors

E-Series
EP2, Analog Output



550919 D

Product Specification

Model EP2 linear-position sensor
single-position measurement



- Linear, absolute measurement
- Non-contact sensing technology
- Non-linearity less than 0.02%
- Repeatability within 0.001%
- Direct position output: Analog 0-10 V
- EMI shielded and CE certified
- Measuring range from 4 to 60 inches
- One year warranty

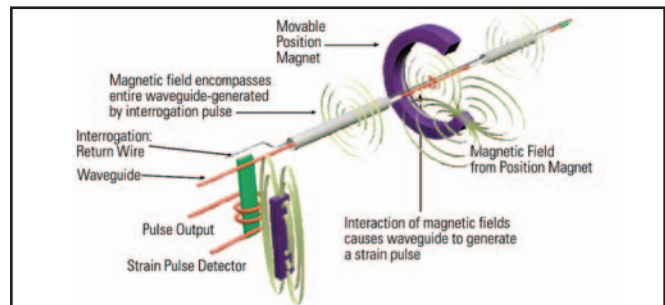

The benefits of magnetostrictive sensing

Temposonics linear-position sensors use the time-based magnetostrictive position sensing principle developed by MTS. Within the sensing element, a sonic-strain pulse is induced in a specially-designed magnetostrictive waveguide by the momentary interaction of two magnetic fields. One field comes from a movable permanent magnet that passes along the outside of the sensor. The other field comes from an “interrogation” current pulse applied along the waveguide. The resulting strain pulse travels at ultrasonic speed along the waveguide and is detected at the head of the

sensing element. The position of the magnet is determined with high precision and speed by accurately measuring the elapsed time between the application of the interrogation pulse and the arrival of the resulting strain pulse with a high speed counter. Using the elapsed time to determine position of the permanent magnet provides an absolute position reading that never needs recalibration or re-homing after a power loss. Non-contact sensing eliminates wear, and guarantees the best durability and output repeatability.



All specifications are subject to change. Please contact MTS for specifications that are critical to your needs.

Temposonics Model EP2 linear-position sensor parameters

There is a new standard of excellence in position sensing. The Temposonics EP2 sensor establishes new performance standards for low-cost, fully-industrial, durable position sensors using the widely preferred magnetostrictive technology.

This principle for accurate and non-contact measurement of linear-position sensing was developed 30 years ago by MTS and is used with outstanding success in a large variety of industrial applications. Industrial applications include harsh environmental conditions such as presses, injection molding, tire presses, rolling plants, tunnel driving machines and hydraulic units.

Analog output

Temposonics E-Series Model EP2 analog output sensors come with integrated analog conditioning electronics. The sensor can be connected to a control system or indicator directly without the need for an additional interface. The built-in microelectronics produce a continuous voltage output that is proportional to the magnet position. The active measurement stroke range is factory set as shown on page 3.

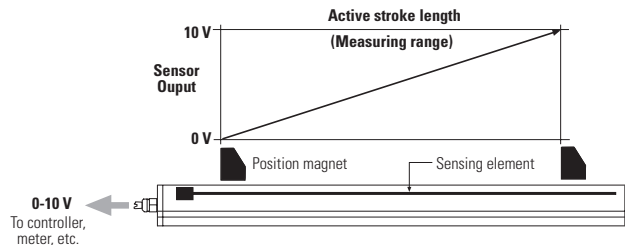

Parameters	Specification
Measured variable:	Displacement
Resolution:	Infinite, restricted by output ripple
Non-linearity:	< ± 0.03% full scale , minimum ± 90 µm
Repeatability:	< ± 0.005% full scale
Outputs:	0 - 10 Vdc Controller input resistance RL >5 kOhm
Update frequency:	> 1.5 kHz
Measuring ranges:	4, 6, 9, 12, 15, 18, 21, 24, 30, 36, 42, 48, 54, 60 in.
Operating conditions:	Temperature: - 40 to 75 °C (- 40 to +167 °F) Relative humidity: 90% no condensation Ingress protection: IP67 Shock test: 50 g (single hit) IEC-Standard 68-2-27 Vibration rating: 5 g/10 - 2000 Hz IEC-Standard 68-2-6
EMC test:	Electromagnetic emission: EN 50081-1 Electromagnetic immunity: EN 50082-2 EN 61000-4-2/3/4/6 Criteria A, CE qualified
Operating voltage:	+ 24 Vdc nominal (-15% or +20%) Polarity protection: up to -30 Vdc Overvoltage protection: up to 36 Vdc Current drain: 50 - 140 mA (stroke length dependent) Dielectric withstand voltage: 500 Vdc (DC ground to machine ground)
Connection type:	Integral cable
Sensor extrusion:	Aluminum
Mounting:	Adjustable mounting feet
Magnet type:	Block magnet with stamped metal carrier

Temposonics Model EP2 linear-position sensor

Dimensions

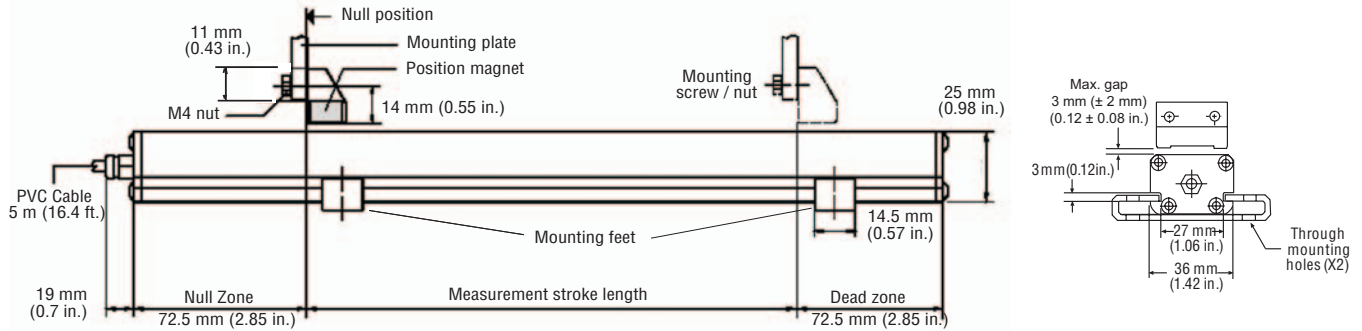

Measurement stroke lengths: 4, 6, 9, 12, 15, 18, 21, 24, 30, 36, 42, 48, 54, 60 in. (only)

Connections

PVC cable, 5 mm dia..

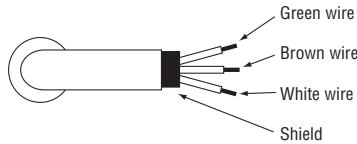

Wiring diagram

Wire color	Signal
Green	0 - 10 V
Brown	+24V Vdc (-15% / +20%)
White	DC Ground (0 V)
Shield	Connected to sensor housing (Appropriate grounding of cable shield is required.)

Sensor mounting

The sensor is fixed onto a flat straight surface of the machine with moveable mounting feet. A pair (2) of mounting feet are provided with each sensor. Additional mounting feet are provided for measurement stroke ranges greater than 48 inches. These mounting feet slide onto the sensor via channels in the extrusion and should be evenly distributed along its length. Refer to the drawing on page 3.

When fastening the mounting feet, 10-32 cap screws are recommended at a maximum torque of (44 in. lbs.).

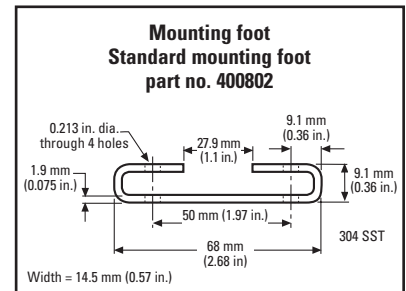

Position magnet

The floating magnet (block style L) mounts on the moving machine part and travels just above the sensor's extrusion. It can be mounted using ferrous metal screws and support bracket. However, the support bracket can not extend beyond 11 mm (0.43 in.) from the top of the magnet, unless it is made of non-ferrous material.

The magnet should be installed with a perpendicular orientation relative to the top surface of the sensor extrusion as shown on page 3. Optimal performance is achieved when this orientation remains consistent throughout the full measurement stroke range.

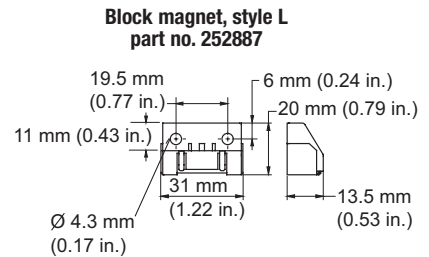

Sensor ordering information

How to order

The EP2 sensor model
With an integral cable, analog output (voltage)

EP2A - _ _ _ _

Measuring stroke length (inches)

004 / 006 / 009 / 012 / 015 / 018 / 021 / 024 / 030 / 036 / 042 / 048 / 054 / 060

Notes:

Temposonics Model EP2 sensors include one magnet (part no. 252887), and two mounting feet (part number 400802) for sensors up to 48 inches of stroke length. Additional mounting feet are included for stroke lengths over 48 inches.

Accessories

Description	Function/Notes	Part no.
Mounting feet, standard (spares)	Model EP2 sensors come with mounting feet	400802
Block style magnet (spare)	Style L "floating" magnet (included with EP2 sensors)	252887

Part Number: 09-06 550919 Revision D

MTS and Temposonics are registered trademarks of MTS Systems Corporation.

All other trademarks are the property of their respective owners.

All Temposonics sensors are covered by US patent number 5,545,984. Additional patents are pending.

Printed in USA. Copyright © 2006 MTS Systems Corporation. All Rights Reserved.



UNITED STATES
MTS Systems Corporation
Sensors Division
3001 Sheldon Drive
Cary, NC 27513
Tel: (800) 633-7609
Fax: (919) 677-0200
(800) 498-4442
www.mtssensors.com
sensorsinfo@mts.com

GERMANY
MTS Sensor Technologie
GmbH & Co. KG
Auf dem Schüffel 9
D - 58513 Lüdenscheid
Tel: +49 / 23 51 / 95 87-0
Fax: +49 / 23 51 / 56 491
www.mtssensor.de
info@mtssensor.de

JAPAN
MTS Sensors Technology
Corporation
Ushikubo Bldg.
737 Aihara-cho, Machida-shi
Tokyo 194-0211, Japan
Tel: + 81 (42) 775 / 3838
Fax: + 81 (42) 775 / 5516
www.mtssensor.co.jp
info@mtssensor.co.jp